



THE MINI CABRIO.



Sky above, road ahead – experience the legendary go-kart feeling in the slick new MINI Cabrio and leave your troubles behind you. Driving with the top down has never felt so good.

STAY OPEN.

Details of fuel consumption and CO₂ emissions for all models, as required under EU law, can be found in the Technical data section on page 44.

For more information on the options available for each model, contact your MINI dealer or visit mini.com/configurator



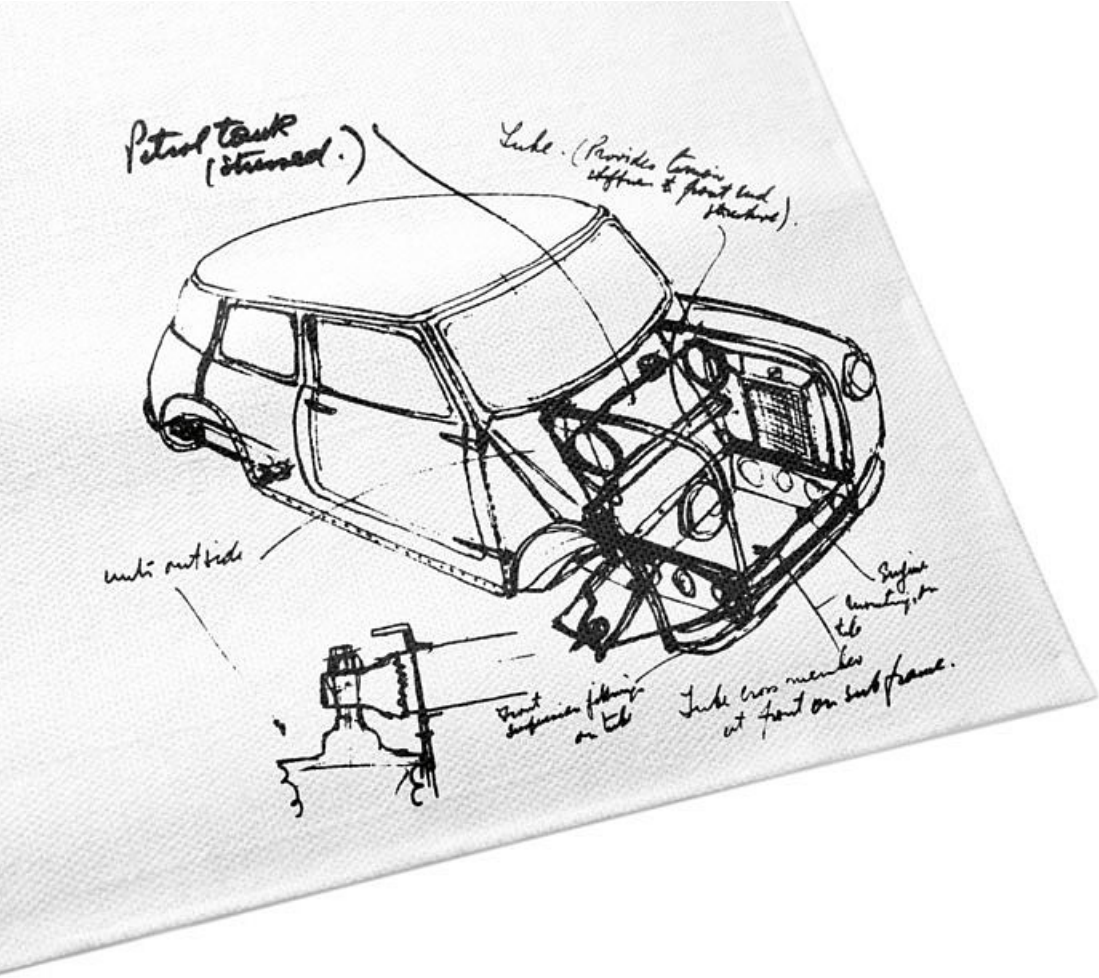

MAKING THE MINI: BREAKING THE MOULD.

When Sir Alec Issigonis sketched his initial idea for the Mini on a tablecloth in 1956, his innovative compact design was the perfect response to some of the biggest automotive questions of his era. Almost everything about it was unconventional: he increased the track width as far as he could, mounted the engine lengthwise, and positioned the instrument cluster centrally for both left and right-hand drive. This ensured maximum space inside the car. The concept was unprecedented – and his revolutionary Mini soon became an icon.

Motorsport legend John Cooper saw star racing potential in the original Mini – so he created a model for the track. Braking, inducing oversteer and then drifting around corners became effortless for rally drivers, thanks to its light weight and short overhangs. Racing around tight bends at high speed, now synonymous with the classic MINI go-kart feeling, laid the foundation for a succession of spectacular wins at the Monte Carlo rally. Here, the Mini proved that agile handling beats sheer power, every time. To honour Cooper’s vision, the thoroughbreds of the MINI range bear the name John Cooper Works.

The compact design of Alec Issigonis and racing pedigree of John Cooper have defined the Mini from the very beginning and remain hallmarks of every iteration to this day. Their legacy of innovation lives on in the latest MINI – and the cutting-edge technology within.











It takes just 20 seconds for the high-quality, electrically operated soft top to fully open or close – even when travelling at speeds of up to 30 km/h. The steep front windscreen offers a clear view of the sky above. When the roof is closed, multiple layers in the soft top provide a high level of sound insulation and a more comfortable drive on longer journeys.

VERY VERSATILE. THE MINI CABRIO CONCEPT.



The woven Union Jack (1) on the soft top, available from the MINI Yours customization programme, echoes the long tradition of MINI and the British heritage of the brand. And if you fancy a bit of fresh air during the journey, just open the integrated sunroof (2).

The Easy Load system increases the size of the luggage compartment opening by holding the retracted soft top above the compartment hatch (3). The open tailgate can then hold up to 80 kg. When the top is closed, the luggage compartment has a generous capacity of 215 l.





WHICH ONE'S YOURS?

There's also more than one MINI to drive away. Whether you go for the One, Cooper/D or Cooper S/SD, each one has a different engine and its own feel behind the wheel. But whichever unit you choose, they all have one thing in common: the power and efficiency of MINI Twin Power Turbo technology.

All MINI models are fitted with a track-style sequential 6-speed manual gearbox as standard. A 6-speed Steptronic automatic transmission is available upon request for all models, while a 6-speed Steptronic Sport gearbox with shift paddles on the steering wheel is also an option for Cooper S/SD and MINI John Cooper Works models. To find out more about the John Cooper Works model, visit your nearest MINI dealer or go online at mini.com/jcw

With optional MINI Driving Modes, you can adapt the performance of your MINI to match your mood and the driving conditions. In the MID and GREEN modes, optional Dynamic Damping Control softens the suspension to keep the drive enjoyably smooth. If you want to feel like you're tearing up tarmac in a go-kart, select SPORT mode.



ONE.

This is what driving a convertible should feel like. The 102-hp/75-kW entry-level MINI One model features a 1.2-l 3-cylinder petrol engine and MINI Twin Power Turbo technology. It comes with a Matt Black safety bar, tailgate handle and exterior mirror caps as well as Brilliant Black radiator grille fins. The exterior mirror caps are also available in body colour.

COOPER.

The 1.5-l 3-cylinder engine in the MINI Cooper Cabrio delivers the perfect blend of power and efficiency. Choose from a 116-hp/85-kW diesel version or a punchier 136-hp/100-kW petrol unit. Like the Cooper S, it sports a Brilliant Black safety bar, tailgate handle and radiator grille fins. The radiator grille and tailgate handle are available with a Chrome finish upon request, as part of the Chrome Line Exterior package.

COOPER S.

The top-of-the-range 2-l 4-cylinder petrol (192hp/141 kW) and 2-l common-rail diesel (170 hp/125 kW) engines deliver all the power you could need. Classic features include the Chrome-rib mesh grille, brake-cooling air intakes in the front bumper, air scoop in the bonnet, diffuser on rear apron and central twin-pipe exhaust system.

FITTED FOR A KING.

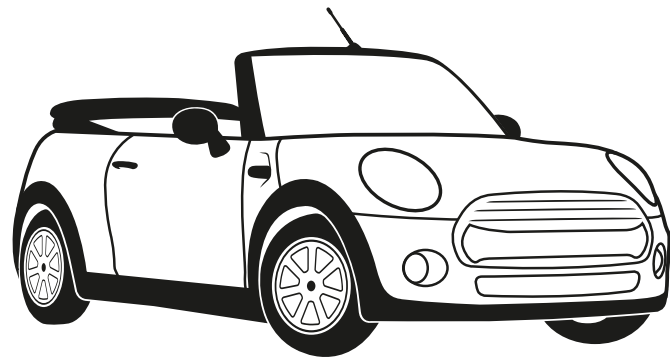

If the practically endless list of individual equipment options puts your head in a spin, keep things simple. Spruce up your MINI Cabrio with one (or more) of our equipment packages. The features in each bundle have been carefully grouped together to complement each other – making your decision that much easier.

What's more, you can easily combine the four options here with other packages, like the Wired (p. 31) or John Cooper Works Exterior/Interior packages.

- ○ ○ ○ SALT.
- ● ○ ○ PEPPER.
- ● ● ○ CHILI.
- ● ● ● JOHN COOPER WORKS CHILI.

The Salt, Pepper, Chili and John Cooper Works Chili packages vary in size, each expanding on the one before it (see above). They contain complementary combinations of individual equipment options designed to suit your needs. See the fold-out page on the right for details. For information on availability, check online or contact your nearest MINI dealer.

mini.com/configurator





SALT.

The Salt equipment package adds a dash of extra comfort and connectivity to the mix. It includes height adjustment for the passenger seat, velour floor mats, the lights and storage packages, air conditioning (One/D and Cooper/D), fog lights and an on-board computer.

PEPPER.

Spice things up a bit with the Pepper package. It has everything in the Salt bundle plus the MINI Excitement package: ambient lighting with toggle switch in the headliner, waterfall lighting, welcome lighting in the front footwells, lighting for door handles and MINI logo projection. You also get:

- + Sports leather steering wheel
- + Automatic air conditioning
- + Rain sensor with automatic headlight activation
- + Exterior mirror caps in body colour for One/D
- + 15" Heli Spoke for One/D
- + 16" Loop Spoke for Cooper/D

CHILI.

On top of all the extras in the Salt and Pepper bundles, the Chili package packs even more racetrack flair and cutting-edge technology into your MINI. Here's what you get:

- + Sports leather steering wheel with multifunction option and cruise control with braking function
- + Diamond cloth/leather, Carbon Black
- + Sport seats for One/D and Cooper/D
- + MINI Driving Modes
- + Headlights and fog lights with LED technology
- + 16" Victory Spoke for One/D
- + 17" Tentacle Spoke for Cooper/D
- + 17" Cosmos Spoke for Cooper S/SD

JOHN COOPER WORKS CHILI.

This package combines everything in the Salt, Pepper and Chili options with the John Cooper Works Exterior and Interior packages (both available separately) for maximum motorsport atmosphere. It includes the following:

- + John Cooper Works sports leather steering wheel with multifunction option and cruise control with braking function
- + Performance Control for One and Cooper
- + John Cooper Works aerodynamic kit
- + Stainless-steel pedals and footrests
- + John Cooper Works door sill finishers and gear lever knob
- + Sports suspension available on request (no charge)
- + 17" John Cooper Works Track Spoke, Black

ADD A DASH OF COLOUR.



Standard colour
Moonwalk Grey

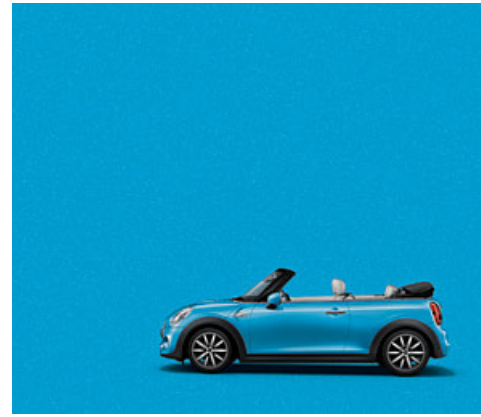

Electric Blue

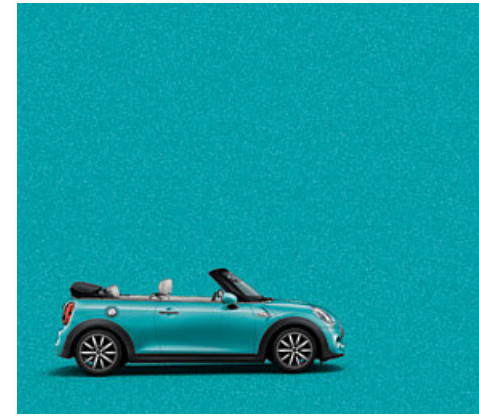

Caribbean Aqua



Deep Blue



British Racing Green



Blazing Red

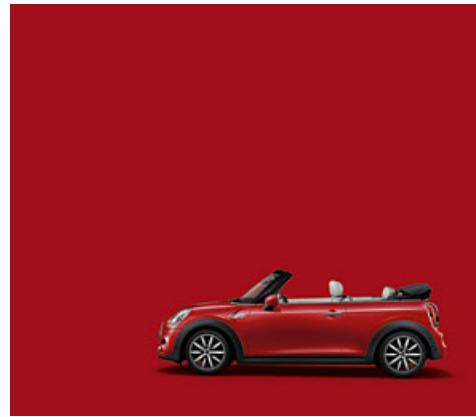

Chili Red

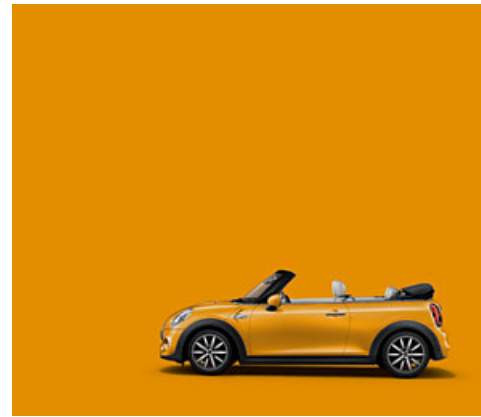

Volcanic Orange



Pepper White



White Silver

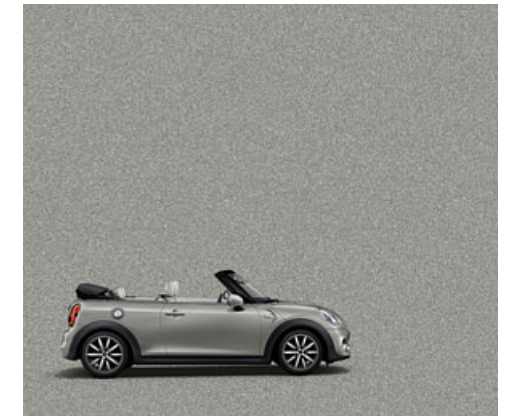

Melting Silver

* Only available for Cooper S.

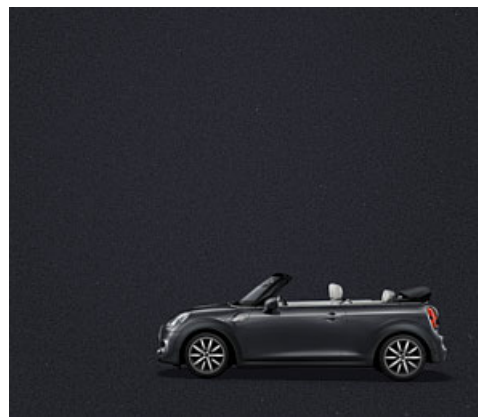

Thunder Grey*



Midnight Black

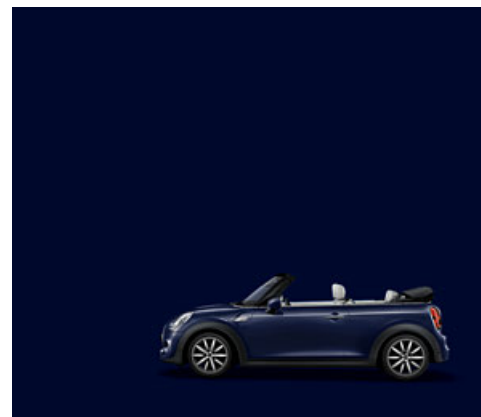

Exclusive colour
MINI Yours Lapisluxury Blue

Soft top.



MINI Yours

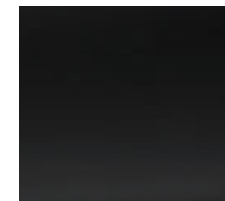

Black

Exterior mirror caps.

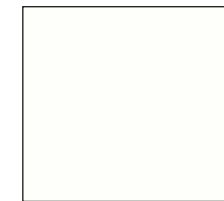

Aspen White

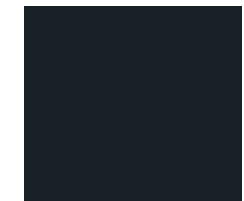

Jet Black

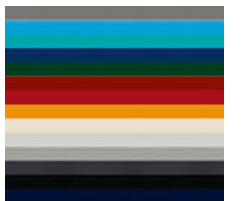

Body colour

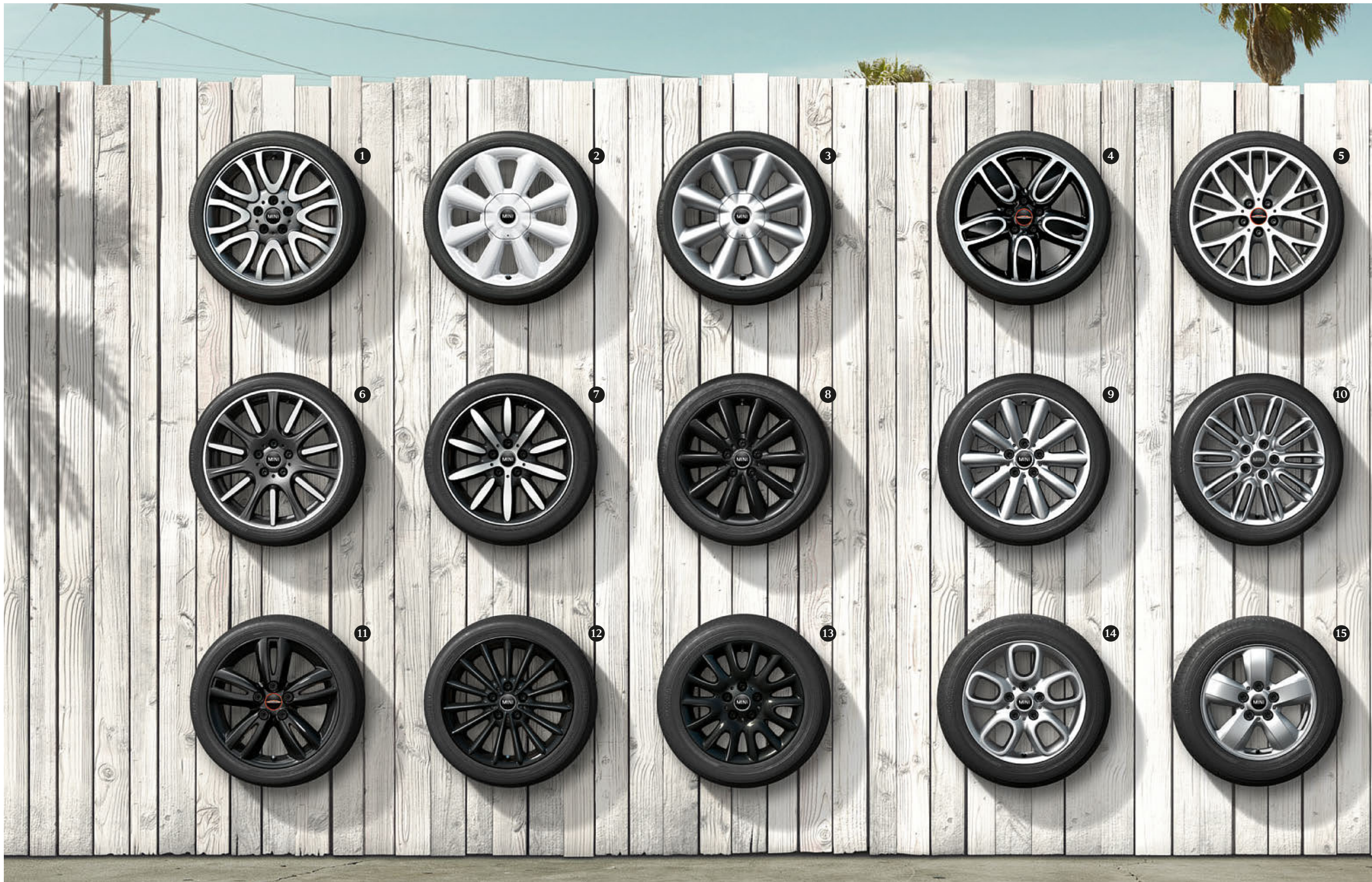

PICK YOUR LOOK.

- ❶ 18" MINI Yours Vanity Spoke, 2-tone
- ❷ 18" Cone Spoke, White
- ❸ 18" Cone Spoke, Silver
- ❹ 18" John Cooper Works Cup Spoke, 2-tone*
- ❺ 18" John Cooper Works Pro Cross Spoke 506, burnished Jet Black**
- ❻ 18" High Spoke 596**
- ❼ 17" Propeller Spoke, 2-tone
- ❽ 17" Cosmos Spoke, Black
- ❾ 17" Cosmos Spoke, Silver
- ❿ 17" Tentacle Spoke, Silver
- ⓫ 17" John Cooper Works Track Spoke, Black*
- ⓬ 17" Multispoke 505, Liquid Black**
- ⓭ 16" Victory Spoke, Black
- ⓮ 16" Loop Spoke, Silver
- ⓯ 15" Heli Spoke, Silver

* Only available in combination with the John Cooper Works Exterior and John Cooper Works Chili packages.
 ** Available at mini.com/accessories

CHOOSE A STYLE THAT SUITS YOU.

Add a personal touch to the interior of your MINI with a choice of 4 Colour Lines, 8 interior surface styles and more. For a detailed look at the options available, just turn the page.

The image below shows the MINI Yours Fibre Alloy Interior Style, Carbon Black Colour Line and Chester leather upholstery in Malt Brown.



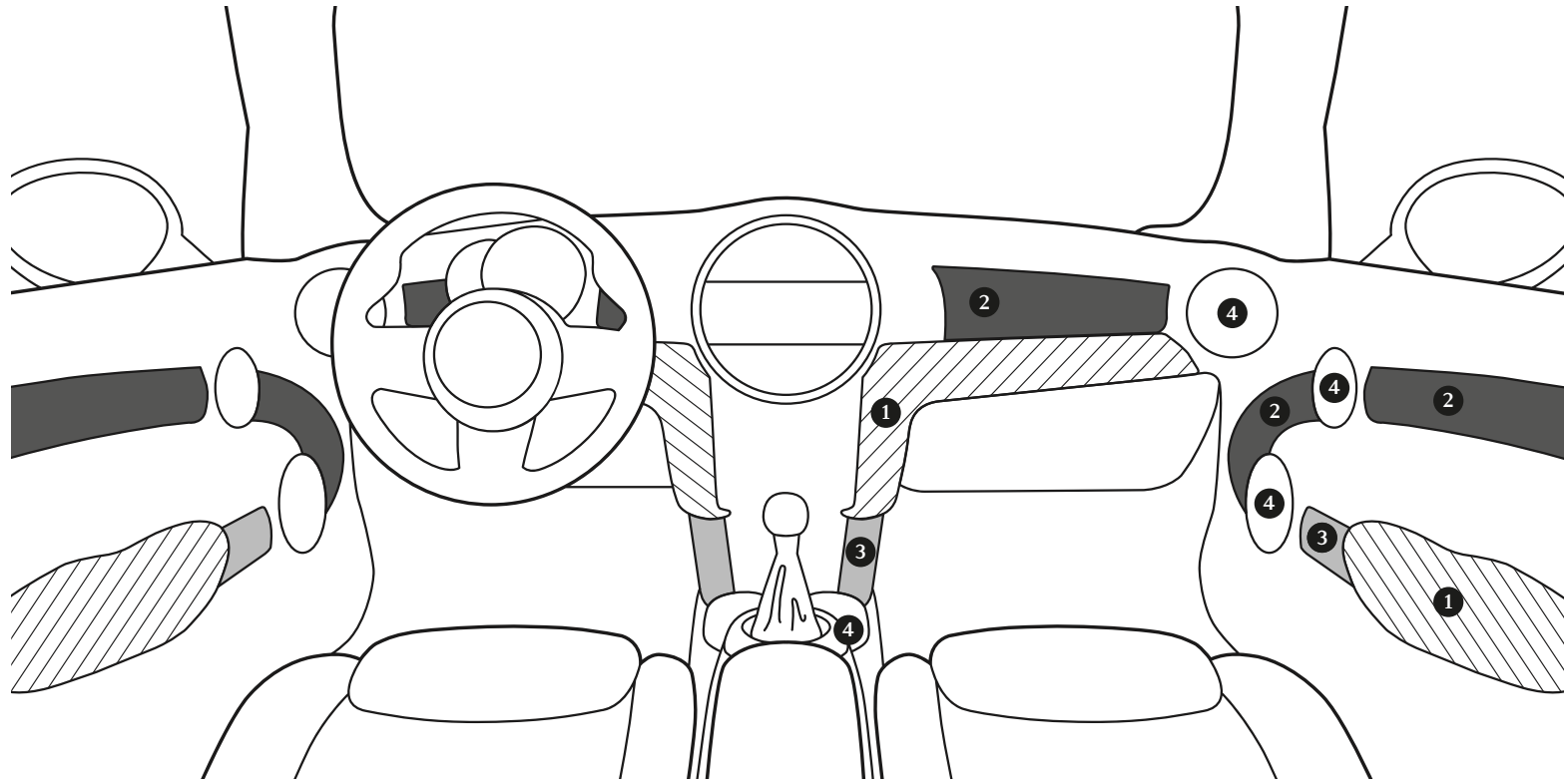

INTERIOR ELEMENTS IN DETAIL.

To help you put together the interior that suits you best, we've divided it up into 4 key design elements. The Colour Line (1) determines the colour of the armrests and knee rolls. The interior surfaces option (2) allows you to choose the material for the decorative door trims and cockpit trims as well as selected structural elements (3). The 3 MINI Yours styles include LED piping, which emits your choice of a range of colours thanks to Ambient Lighting. To round it all off, you can choose the colour for the decorative rings (4) around the loudspeakers, door handles, air vents and gear selector lever.

[mini.com/configurator](https://www.mini.com/configurator)

1 4 Colour Lines.



Carbon Black



Dark Truffle

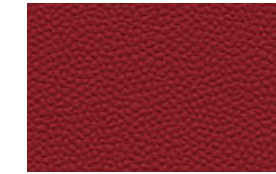

Glowing Red

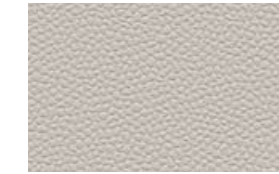

Satellite Grey

2 8 interior surface styles.

The examples below show the materials for the cockpit trim (left) and decorative door trim (right).



MINI Yours Interior Style
Dark Cottonwood

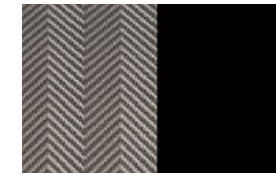

MINI Yours Interior Style
Fibre Alloy



MINI Yours Interior Style
Off-White

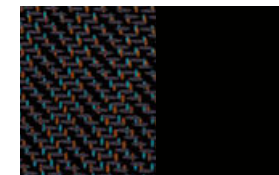

Firework

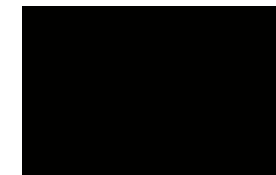

Piano Black



Dark Silver

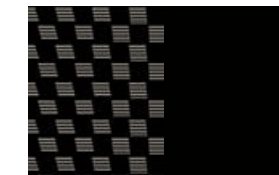

Black Chequered

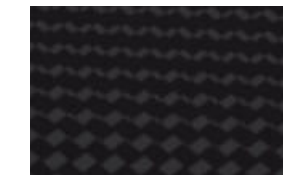

Hazy Grey
(no decorative door trim)

3 2 structural element styles.

Piano Black structural elements are the ideal complement to the optional interior surface styles. The exception here is the MINI Yours Interior Style Off-White: the structural elements are finished in Brilliant Off-White.

4 3 decorative ring styles.

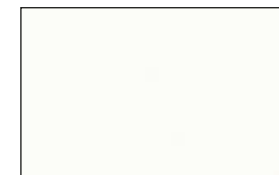

Porcelain Matt White*

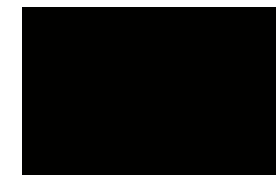

Piano Black



Chrome Line

* Only available in conjunction with MINI Yours Interior Style Off-White.

AT HOME IN SECONDS.



Chester leather sport seat,
Malt Brown



John Cooper Works
Dinamica/leather sport seat,
Carbon Black

COMFORT OF EVERY KIND.



Lounge leather sport seat,
Satellite Grey



Cross Punch leather sport seat,
Dark Truffle



Black Pearl cloth/
leatherette sport seat,
Carbon Black



Diamond cloth/leather sport seat,
Carbon Black



MINI Yours Lounge leather*,
Carbon Black

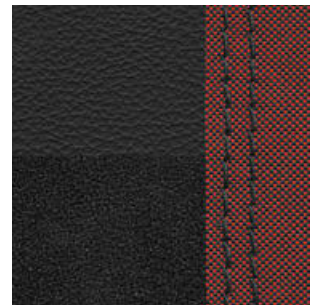

John Cooper Works
Dinamica/leather, Carbon Black



Chester leather*,
Malt Brown



Lounge leather*,
Satellite Grey

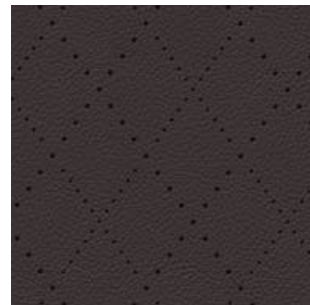

Cross Punch leather*,
Dark Truffle



Cross Punch leather*,
Carbon Black



Diamond cloth/leatherette,
Carbon Black

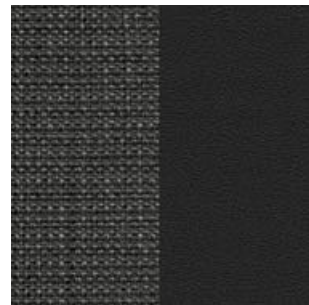

Black Pearl cloth/leatherette,
Carbon Black

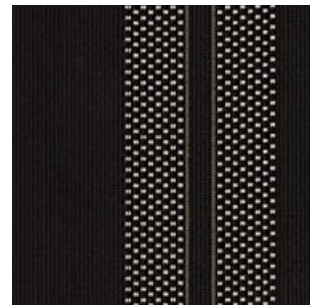

Double Stripe cloth,
Carbon Black

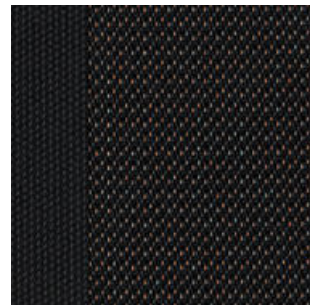

Firework cloth,
Carbon Black

MINI YOURS.

The Carbon Black MINI Yours seat in luxurious Lounge leather isn't just made – it's crafted. The smooth feel of the leather against your hand, the detailed stitching of the Union Jack in the headrest, the braided edging ... the beauty is in the detail.

[mini.com/configurator](https://www.mini.com/configurator)



* Leather upholstery includes seats (base and backrest), and front and rear headrests.

IT'S IN YOUR HANDS.

The choice is yours. Check out the exclusive MINI Yours steering wheel (1), made from soft nappa leather, with Grey stitching and a Union Jack emblem, or the non-slip John Cooper Works sports leather steering wheel (2) with John Cooper Works badge, perforated leather and contrast stitching in Chili Red. Once you get your hands on one, you won't want to let go.



1 MINI Yours sports leather steering wheel with multifunction option

2 John Cooper Works sports leather steering wheel with multifunction option

3 3-spoke sports leather steering wheel with multifunction option

4 2-spoke standard steering wheel



BIG ON SMALL DETAILS: MINI YOURS.

The sewing needle and Union Jack in the MINI Yours logo epitomize the craftsmanship and British heritage of the range. Whether you go for the exclusive exterior colour MINI Yours Lapisluxury Blue, MINI Yours Vanity Spoke 2-tone light-alloy wheels, MINI Yours Interior Styles, the MINI Yours sports leather steering wheel in soft nappa leather, the Carbon Black MINI Yours seat or the woven Union Jack soft top, every item is crafted by hand using top-quality materials, and each has its own story to tell.





MINI CONNECTED: HELLO WORLD.

Between MINI Connected and its compatible apps, you've got everything you could need to take the hassle out of your journey – or inject a few more thrills into it. Be it loading up your very own smartphone-based personal assistant or choosing music from one of countless playlists, you can do it all from behind the wheel.

The development of MINI Connected is an ongoing process. Updates are sent directly to customers – and integrated into the product – via the Open Mobility Cloud. This means that app screens, interfaces and other features shown on the following pages may soon change. And if they do, it'll be change for the better. For the latest information on MINI Connected features and availability in your country, go online at

mini.com/connected

WIRED



With the Wired package you can take full advantage of the MINI Connected world of infotainment. It comes with the Professional navigation system with 22.4-cm/8.8" screen and operation via the MINI Touch Controller on the centre console. There's also a snap-in adapter preparation in the centre armrest: this allows you to link up your smartphone to your MINI via the appropriate snap-in adapter and make and receive calls via the external antenna. Other features include a multifunction steering wheel, voice control, 3D satellite map view, MINI Connected, 20 GB of entertainment storage and much more.

Model illustrated: MINI 3 Door

LEAVE ORGANIZED. ARRIVE ENERGIZED.

LET MINI CONNECTED SHOW YOU THE WAY.

And we're off: Set your destination and MINI Connected lets you know when it's **time to go**.

Good to know: Before you head off, MINI Connected displays journey times to **frequently visited places**.

With MINI Connected you can share your estimated **arrival time** with others, so no-one's kicking their heels.

How long does it take? Should I stop for petrol on the way? **MINI Status** answers all the important questions before you leave.

It's about to rain: The **rain warning function** shows rain on the route ahead and guides you to the nearest parking spot so you can close the roof.

Online radio, playlists, news, audiobooks – there's a handy **MINI Connected ready app** to suit every whim.

MINI CONNECTED FUNCTIONS AT A GLANCE:



VEHICLE STATUS AND DESTINATIONS.

The MINI Status display on your smartphone – in a classic MINI design with Union Jack – provides a handy overview of key information, such as how far you are from your destination, the current range, and remaining journey time.



VEHICLE SEARCH.

Not sure where you left your MINI? Check your smartphone to find the quickest way back.



TIME TO GO.

MINI Connected sends updates to your smartphone or Apple Watch, reminding you when it's time to make your way to a saved/learned destination. The latest online traffic updates are taken into account when calculating the time.



FREQUENTLY VISITED PLACES.

MINI Connected shows all previously learned or saved destinations and calculates the time it takes to reach them from your current location, using real-time traffic information. It saves time – and helps you stay on top of things.



ONLINE SEARCH.

Going shopping or eating out? Once you've found somewhere suitable using Online Search, you can send the address to the navigation system, and the phone number to your smartphone, so you can book a table.



SHARE YOUR ARRIVAL TIME.

Great for groups of friends coming from all different directions: you can send your arrival time (calculated using real-time traffic updates) to smartphone contacts.



MINI CONNECTED READY APPS.

An ever increasing number of pre-configured apps for MINI Connected allow you to use all your favourite smartphone features on the move. Keep your spirits up with your choice of Spotify playlists, podcasts, audiobooks and other music apps.



RAIN WARNING FUNCTION.

The rain warning function warns of any adverse weather up ahead, giving plenty of notice so you can put the roof up. And when you've parked your MINI Cabrio with the roof down, it lets you know when to close it if showers are forecast.



CALENDAR INTEGRATION.

MINI Connected can import all destinations from your smartphone calendar. It saves addresses in the navigation system and reminds you of when you need to leave.



IMPORT DESTINATION FROM SMARTPHONE TO NAVIGATION SYSTEM.

As long as your smartphone is linked to your vehicle, destinations (learned, saved or imported from your calendar) are automatically saved to the navigation system. Route guidance starts automatically (depending on equipment fitted).



ONLINE TRAFFIC MAP.

A real-time traffic check helps you spot and bypass sudden bottlenecks. Use the zoom function to pinpoint alternative routes.



THE BEST CONNECTIONS ARE ALSO THE SIMPLEST.

MINI Connected and a smartphone is all you need to access the new Open Mobility Cloud, developed by MINI. Via the Cloud, MINI Connected becomes your very own in-car PA that even helps you get from A to B when you aren't behind the wheel. With the Journey Management feature, planning is easy. Appointments, destinations and routes are all taken care of, taking the hassle out of being on time, and letting you focus on the fun stuff. Speaking of fun, there's also a set of MINI Connected ready Apps. These allow you to access countless apps from other providers, like Spotify, TuneIn Radio, Amazon Music and much more.

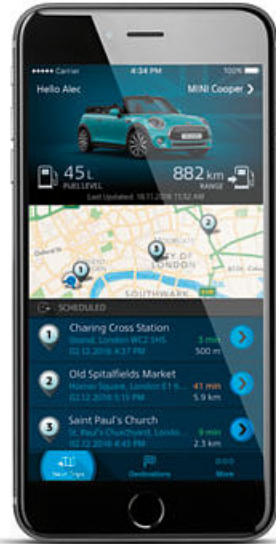

CHOOSE YOUR INTERFACE.

1 RADIO MINI BOOST.

The Radio MINI Boost, with USB audio, AUX-IN interfaces and a 4-line display, is fitted as standard.

3 MINI NAVIGATION SYSTEM.

Leading the way: a first-class navigation system with GPS, TMC and USB updates. Upgrade for the Radio MINI Visual Boost. Easily operated via the MINI Controller.

2 RADIO MINI VISUAL BOOST.

Complete with 16.2-cm/6.5" screen, ergonomic MINI Controller, MINI Connected interface and Bluetooth hands-free kit.

4 WIRED EQUIPMENT PACKAGE.

The MINI Centre Instrument with 8.8" screen (22.4-cm diagonal) is just one of the host of features included in the Wired package, which represents the next level in in-car connectivity.



THE BEST JOURNEYS BEGIN WITH PEACE OF MIND.

1 Never lose sight of the important things: the MINI Head-Up Display projects key driving information into the driver's line of sight without obstructing his view of the road. Depending on the optional equipment fitted, this data can include speed limits, navigation instructions and cruise control settings.

2 Instead of roll-over bars, a roll-over protection system in the bodywork of the vehicle deploys in milliseconds to protect passengers, if required. It's hidden out of the way, maintaining rearward visibility for both driver and passenger. This maintains the minimalist contours of the vehicle, while ensuring driver and passenger safety in the event of an accident.

3 A high-resolution reversing camera displays a clear view of the area behind the car in the MINI Centre Instrument.

The Driving Assistant is a camera-based solution that increases safety on the road for you and others around you. It recognizes and reports speed limits and no-overtaking zones. When travelling at speeds between 10 and 60 km/h, the Pedestrian Collision and Forward Collision

Warning systems, both with city brake function, warn drivers and automatically brake if a potential collision is detected. At higher speeds, the Forward Collision Warning also registers potential collisions with vehicles in front and preconditions the brakes for rapid responses and shorter stopping distances. If an accident is unavoidable, the city brake function helps reduce impact speed. (not shown)





THE EXCLUSIVE JOHN COOPER WORKS PACKAGES.



We've put together a range of options to help you create a red-hot John Cooper Works look. The striking John Cooper Works exterior package includes imposing front and rear aprons, painted side skirts and optional 2-tone 18" Cup Spoke light-alloy wheels. If you want the motorsport feel inside as well as out, go for the John Cooper Works Interior package, which includes stainless-steel pedal pads.

For increased lateral support around corners, John Cooper Works sport seats in Dinamica/leather can be fitted upon request. A 6-speed Steptronic Sport gearbox with paddles on the steering wheel is also available as an option.*

The John Cooper Works Chili package is the ultimate upgrade. It covers everything in the Exterior and Interior packages and more. See page 17 for details.

* Exclusive to MINI Cooper S/SD models.



JOHN COOPER WORKS TUNING: TOP PERFORMANCE.

For even more motorsport flair, you can beef up your MINI with optional John Cooper Works Pro Accessories – your local MINI dealer will have everything on hand for both new cars and retrofitting your MINI. Accessories include burnished 18" Cross Spoke 506 light-alloy wheels in Jet Black, John Cooper Works Pro aerodynamic components, Carbon exterior mirror caps,

side scuttles, sport stripes, Racing side stripes and Black Line bezels for the headlights. For a suitably nerve-tingling sound, add the optional John Cooper Works Pro Tuning kit, which enhances engine output and features the John Cooper Works Pro valve silencer and a tailpipe trim in Carbon or Chrome.

John Cooper Works Pro Tuning
mini.com/accessories





DRIVING THE FUTURE OF MOBILITY.

We have never been so connected – and life has never been so fast-paced. So we need vehicles that can keep up with our hectic lifestyles. And this is why a MINI excels in many different ways. A MINI is all about being yourself, enjoying your journey and turning heads along the way.

But it's also about having the right mindset. This means loving what we do. And recognising the value in certain things, whether it's because they mean something, because they're important or because they look good.

Since 1959, we have strived to retain what sets MINI apart while creating something new. We want to inspire others to help us develop better ways of going places, which we can appreciate today – and in the future.

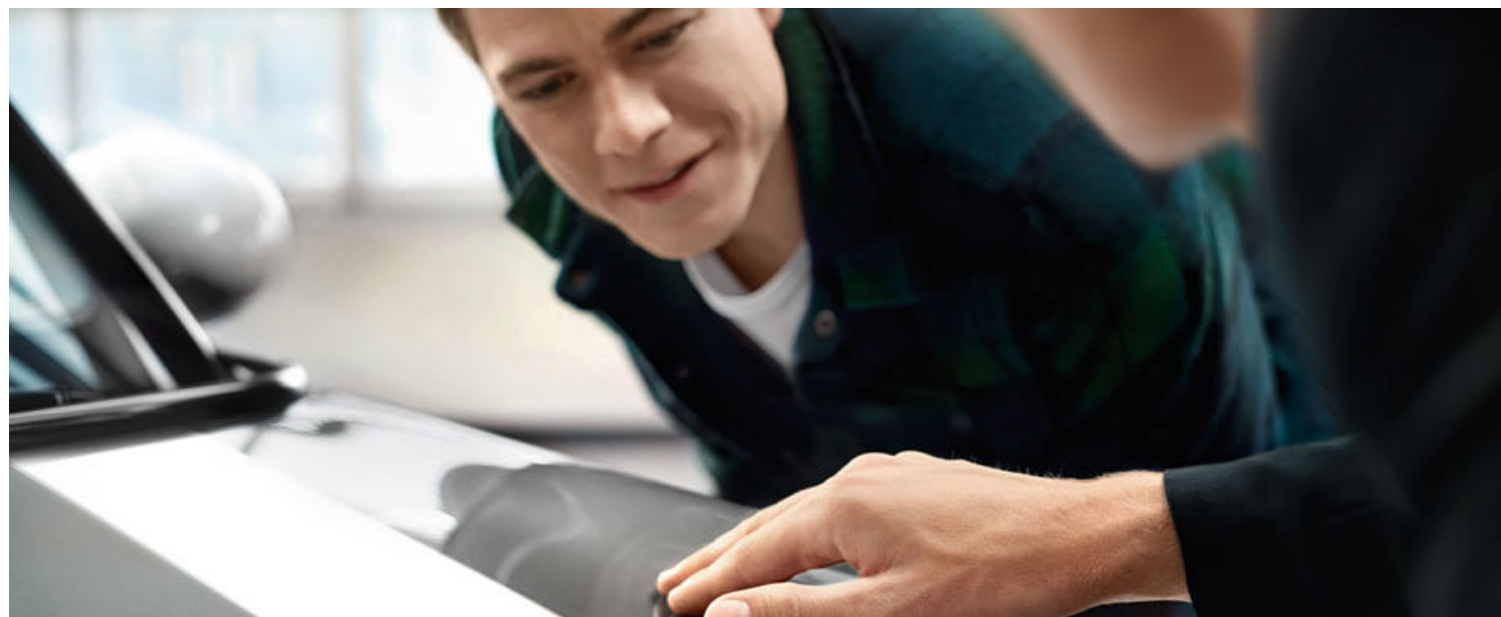

MINI SERVICE.

We've got everything covered.

Our service experts are as passionate about your MINI as you are. They're specially trained to keep it in top shape, so for electrical or mechanical defects, cosmetic or bodywork repairs, or even simply fitting MINI Original Parts, your MINI will be in the best possible hands.

MINI knows best.

Since you can't always think of everything when on the road, your MINI uses its head too. The Condition Based Service feature automatically reminds you when its next service is due, via the MINI Centre Instrument. The MINI Teleservices feature automatically transfers the most important vehicle data to MINI via a built-in SIM card. Your local MINI Service Centre will then contact you to make an appointment if any maintenance is necessary. What's more, in the unlikely event of a breakdown, you can also contact the specialists on our MINI Breakdown Service team directly. If you don't need to use the service, you can deactivate it at any time. The Intelligent Emergency Call option is required to use MINI Teleservices.

At a glance: MINI Service Inclusive.

Thanks to MINI Service Inclusive and MINI Service Inclusive Plus, there's no need to worry about maintenance and repair costs: a single fixed amount for maintenance covers all the services included in your chosen package for up to 6 years and 120,000 kilometres. It's easy to calculate, and MINI Service Inclusive represents a significant saving in cost compared to individually paid-for trips to your MINI Service Partner. Both packages provide quality you can count on, too: qualified MINI Service specialists, state-of-the-art diagnostics tech and top-quality MINI Original Parts guarantee first-class service, every time, so your MINI retains its value over the years and miles.

We'll keep your MINI mobile.

MINI Breakdown Service is there when you need it, 24 hours a day, 365 days a year. We offer comprehensive roadside assistance if you have a breakdown, and incidental-costs insurance for accidents and theft. Specially trained MINI technicians provide solutions over the phone or on site, whatever the time, and wherever in the world you may be. Find out more at mini.com



MINI FINANCIAL SERVICES.

The key to the car of your dreams.

MINI Financial Services* represents the quickest way to the car of your dreams. With MINI Leasing, you pay to use the vehicle and not a penny more. MORE MINI packages provide a host of attractive extras, such as suitable insurance**, a tailored service deal or even a combination of both.

If you want to own a MINI but stay flexible with your financing, you'll find a favourable deal with MINI Finance. And for total peace of mind, check out MINI Car Insurance**.

Find out more about MINI Financial Services online at mini.com or visit your local MINI dealership***.

* MINI Financial Services is a trade name of BMW Bank GmbH, Heidemannstr. 164, 80939 Munich, Germany.
 ** Contractual partner and risk carrier is Allianz Versicherungs-AG.
 *** Vehicle also includes a service package. See service package agreement for details.

Warranty.

Every MINI is supplied with a 2-year dealer warranty against manufacturing defects. The MINI dealership where the purchase was made is responsible for honouring the warranty. Repair work can be carried out at any authorized MINI dealer, MINI Service Authorized Workshop or any other service centre authorized by MINI. Defects arising in the first 6 months after purchase are deemed by law to have existed at the time of purchase and the dealer has the onus of proving that the vehicle is not defective due to a manufacturing defect. Every MINI also comes with a 12-year anticorrosion warranty, which covers the vehicle against rusting of the body panels. The painted surfaces of the car are covered by a 3-year warranty. This warranty does not cover damage to the vehicle body or under-body caused by stone impacts, scratches or dents, accident damage or other damage caused by environmental factors. Failure to comply with the service schedule provided by the manufacturer may invalidate this warranty.

Recycling.

At every stage, from design to disassembly, recycling is central to the MINI philosophy. For example, all the materials used in each vehicle's manufacture are selected because they can be used in the most sustainable and environmentally friendly way possible. That way, every MINI can be efficiently and ecologically recycled when its driving days are finally done. We've been working on this approach since 1994 at the BMW Group Recycling and Disassembly Centre in Munich, the only facility of its kind. Your MINI dealer will be pleased to advise you on the disposal of your old vehicle, or you can visit mini.com

TECHNICAL DATA FOR THE MINI CABRIO.

Engine ^{1,2}		One	Cooper	Cooper D	Cooper S	Cooper SD
Cylinders/layout/valves per cylinder		3/in-line/4	3/in-line/4	3/in-line/4	4/in-line/4	4/in-line/4
Capacity	cm ³	1198	1499	1496	1998	1995
Stroke/bore	kW/hp/ rpm	75/102/ 4000-6000	100/136/ 4400-6000	85/116/ 4000	141/192/ 5000-6000	125/170/ 4000
Max. torque/revs	Nm/rpm	180/1400-3900	220/1250-4300	270/1750	280/1350-4600	360/1500-2750
Compression ratio/recommended fuel	:1	10.2/RON 91 MIN	11/RON 91 MIN	16.5/Diesel	11/RON 91 MIN	16.5/Diesel
Performance¹						
Max. speed	km/h	190	208 [206]	195 [195]	230 [228]	[218]
Acceleration 0-100 km/h	sec	10.6	8.8 [8.7]	9.9 [9.9]	7.2 [7.1]	[7.7]
Acceleration 80-120 km/h (5th gear)	sec	13.2	10.3	9.7	6.7	-
Fuel consumption^{1,2}						
Urban	l/100 km	6.0-5.9	6.0-5.9 [6.3-6.2]	4.5-4.4 [4.5-4.4]	7.9-7.8 [7.2-7.1]	[5.0-4.9]
Extra-urban	l/100 km	4.6-4.4	4.5-4.3 [4.7-4.5]	3.7-3.5 [3.9-3.7]	5.1-4.9 [5.0-4.8]	[4.1-3.9]
Combined	l/100 km	5.2-5.0	5.1-4.9 [5.3-5.1]	4.0-3.8 [4.1-3.9]	6.1-6.0 [5.8-5.6]	[4.4-4.3]
CO ₂ emissions (combined cycle)	g/km	120-116	118-114 [123-119]	105-100 [109-104]	142-139 [134-131]	[116-113]
Tank capacity, approx.	l	40	40	44	44	44
Range	km	800	815 [785]	1160 [1130]	735 [785]	[1025]
Weight¹/Luggage capacity¹						
Unladen weight EU ³	kg	1280	1280 [1305]	1320 [1340]	1350 [1370]	[1380]
Max. permitted weight	kg	1670	1670 [1695]	1710 [1730]	1745 [1765]	[1770]
Max. permitted load	kg	460	460	460	460	460
Max. permitted axle load, front/rear	kg	900/800	910 [940]/800	935 [955]/805	955 [975]/810	[970/810]
Luggage capacity	l	215	215	215	215	215
Wheels						
Tyre dimensions		175/65 R15 84H	175/65 R15 84H	175/65 R15 84H	195/55 R16 87W	195/55 R16 87W
Wheel dimensions		5.5 J x 15	5.5 J x 15	5.5 J x 15	6.5 J x 16	6.5 J x 16
Material		Steel	Lightweight alloy	Lightweight alloy	Lightweight alloy	Lightweight alloy

MINI CABRIO DIMENSIONS.

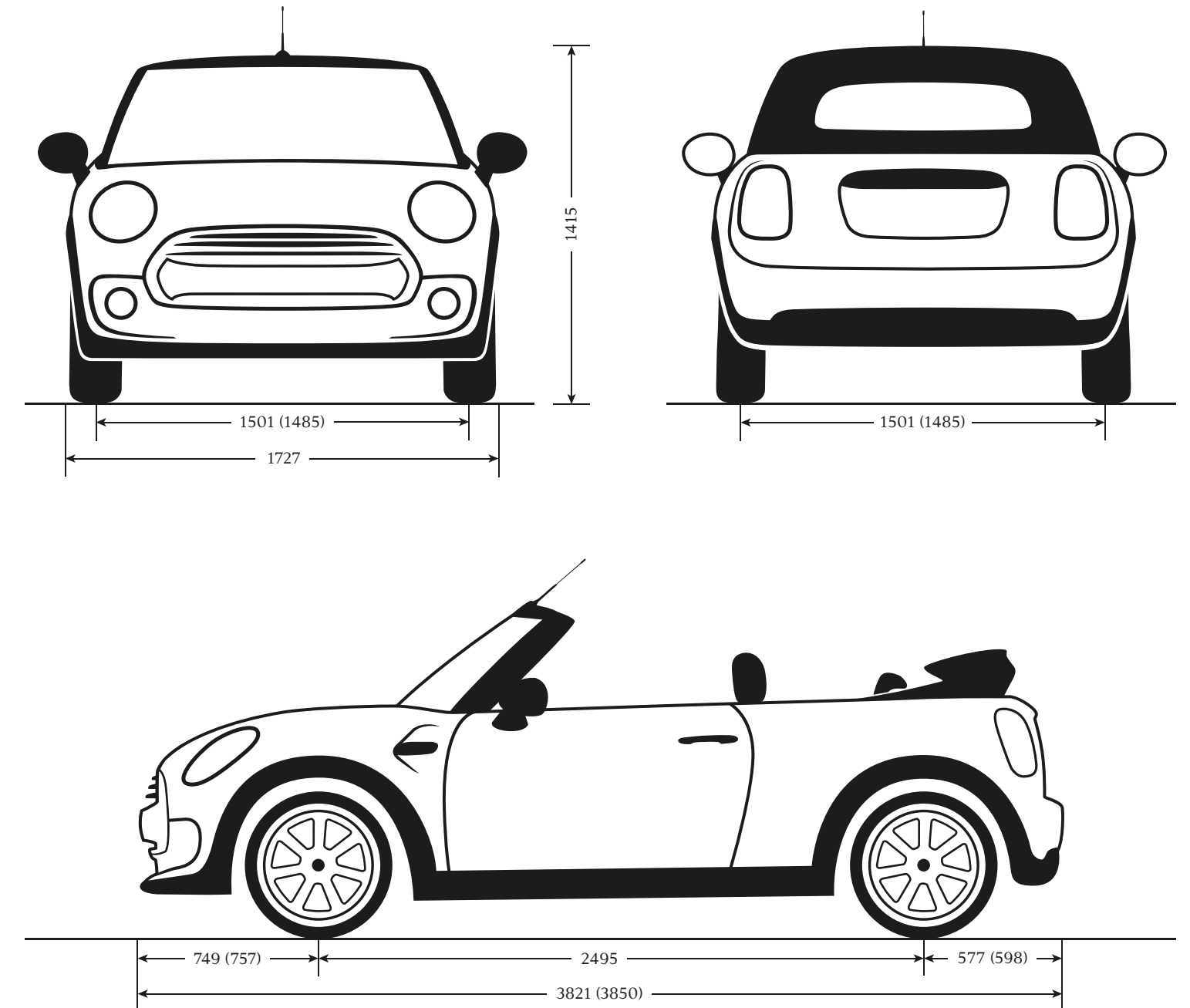

All figures in mm.
Cooper S figures in brackets.

¹ All figures relate to vehicles with the standard 6-speed manual transmission. Figures in brackets relate to vehicles with 6-speed Steptronic transmission.

² All MINI models comply with the EU6 exhaust emissions standard. Fuel consumption is determined in accordance with the ECE driving cycle (as defined in directive 80/1268/EEC), made up of approximately one third urban and two thirds extra-urban driving (based on the distance covered). CO₂ emissions are measured separately from fuel consumption. Figures relate to standard-specification vehicles and may vary significantly where optional equipment (including wider tyres) is fitted. Figures for fuel consumption and CO₂ emissions may vary depending on the wheels and tyres fitted.

³ Assuming car is fuelled to 90% of usable tank capacity, and allowing 68 kilograms for the driver and 7 kilograms for luggage. Figure quoted is for standard-specification vehicles. Optional equipment will increase this figure.



WE'VE SAVED THE BEST FOR LAST: THE TEST DRIVE.

What's the point of revving yourself up without taking it for a spin? Get behind the wheel. Make yourself comfortable in the driver's seat. Listen to the satisfying sound the door makes as it closes behind you. Fasten your seat belt. Adjust the rear-view mirror and start the engine. A whole new experience awaits you: a drive like no other, guaranteed to inspire. So what are you waiting for? Arrange a test drive with your MINI dealer and find out what it feels like to drive a MINI.

mini.com



The models, standard and optional equipment and combinability of options in this catalogue relate to cars supplied by BMW AG for the German market. The availability of standard and optional equipment, and the combinability of options, may vary for all models in this brochure after going to press (on 19 Dec 2016), and may vary from country to country within the European Union. For detailed information about the situation in your country, please contact your authorized MINI dealer. Subject to changes in design and equipment.

© BMW AG, Munich, Germany. Not to be reproduced, wholly or in part, without the written permission of BMW AG, Munich.

For more information, visit
mini.com
or contact MINI Infoservice.



[facebook.com/mini](https://www.facebook.com/mini)

MINI ORIGINAL ACCESSORIES
[mini.com/accessories](https://www.mini.com/accessories)

MINI COLLECTION
shop.mini.com

March 2017

